



# MCCC

MALAYSIAN CONCRETE CANOE COMPETITION

# 2017

Patronage by

**YB DATUK WIRA DR. ABU BAKAR BIN MOHAMAD DIAH**

**Organiser**



**In collaboration with**



**Supported by**



**C&CA**



**Rules and Regulations**

REV 2.0

## Table of Contents

1	GENERAL RULES AND ELIGIBILITY REQUIREMENTS .....	1
1.1	QUALIFICATIONS .....	1
1.2	REGISTERED PARTICIPANTS .....	1
1.3	TECHNICAL ASSISTANCE.....	1
1.4	SPONSORSHIP.....	1
1.5	REQUESTS FOR INFORMATION (RFI).....	1
1.6	GENERAL INFORMATION .....	1
1.7	SPIRIT OF THE COMPETITION .....	1
1.8	CANOE REMOVAL .....	1
1.9	SAFETY .....	2
2	CONCRETE CANOE.....	2
2.1.1	GENERAL.....	2
2.2	DIMENSIONAL CONSTRAINTS .....	2
2.2.1	Length .....	2
2.3	CONCRETE AND REINFORCEMENT .....	2
2.4	PADDLES.....	2
2.5	SLIP RESISTANT MATERIAL .....	2
2.6	FLOTATION .....	2
2.6.1	Requirements .....	2
2.6.2	Flotation Test .....	3
2.7	REPAIRS .....	3
2.7.1	Repairs Made During Competition.....	3
2.7.2	Repair Materials.....	3
3	CONCRETE .....	3
3.1	GENERAL.....	3
3.2	REQUIREMENTS.....	4
3.2.1	Cement .....	4
3.2.2	Density .....	4
3.3	Documentation.....	4
3.3.1	Mix Proportion Table.....	4
3.3.2	Engineering properties .....	4
3.3.3	Material Data Sheets (MDS).....	4
3.3.4	Aggregate Sample(s).....	4
3.3.5	Concrete Sample(s).....	4
4	REINFORCEMENT .....	6

4.1	GENERAL .....	7
4.2	MATERIALS .....	7
4.3	MEASUREMENT .....	7
4.3.1	Percent Open Area (POA).....	7
4.4	DOCUMENTATION .....	8
4.4.1	Reinforcement and Percent Open Area (POA) Calculations .....	8
4.4.2	Reinforcement Samples .....	8
4.4.3	Material Technical Data Sheets .....	8
5	FINISHING.....	8
5.1	GENERAL .....	8
5.2	LETTERING.....	8
5.3	GRAPHICS.....	8
5.4	DOCUMENTATION .....	8
5.4.1	Material Data Sheets .....	8
6	DESIGN PAPER .....	9
6.1	GENERAL REQUIREMENTS .....	9
6.2	REPORT SUBMISSION .....	9
7	RACE RULES and REGULATIONS.....	10
7.1	GENERAL .....	10
7.2	RACE RULES .....	10
7.3	Sportsmanship.....	10
7.4	RACE COURSE .....	11
7.4.1	General Requirements.....	11
7.4.2	200-meter Endurance Course.....	11
7.4.3	100 Sprint Course.....	11
7.5	RACE PENALTIES.....	11

# 1 GENERAL RULES AND ELIGIBILITY REQUIREMENTS

## 1.1 QUALIFICATIONS

All qualifying teams shall be civil engineering students. As representatives of civil engineering profession, all competition participants are expected to and must act professionally and courteously.

## 1.2 REGISTERED PARTICIPANTS

A team may register up to a maximum of five (5) male and five (5) female participants. Teams may have less than ten (10) registered participants. Registered participants are the only persons eligible to present or answer questions for the Oral Presentation and/or compete in the races. No change of participants is allowed after registration is closed.

## 1.3 TECHNICAL ASSISTANCE

Students are encouraged to contact corporate sponsors to request samples, materials and/or relevant product information. Contact information for national sponsors can be accessed through the company logo links available on the official MCCC website.

## 1.4 SPONSORSHIP

The use of trade and company names for services, products, and intellectual property shall be permitted in the design report, oral presentation and product display for informational purposes only.

## 1.5 REQUESTS FOR INFORMATION (RFI)

Requests for Information (RFI) should be directed via e-mail to the Committee on Malaysia Concrete Canoe Competition (MCCC) at [mymccc2017@gmail.com](mailto:mymccc2017@gmail.com). Official responses will be posted to the MCCC 2017 Facebook page. The cut-off date for submitting a RFI is **Friday, June 17, 2017**. Those received after this date will not be acknowledged or addressed.

All RFIs will be made public. The MCCC has a Facebook Page (<https://www.facebook.com/mccc2017>) to post relevant information including RFI responses. This Facebook page is not intended for the submission of RFIs and any posted to the page will not be addressed by the MCCC.

## 1.6 GENERAL INFORMATION

General information on the competition as well as registration information for the Malaysia Concrete Canoe Competition is located on the ACI Malaysia website. Students shall be responsible for registration materials and Design Paper submittal deadlines published on these websites.

## 1.7 SPIRIT OF THE COMPETITION

Under the "Spirit of the Competition," the judges and/or the MCCC have the final authority to determine what constitutes a violation and may take appropriate action towards point deduction or disqualification. The decision by judges is final.

## 1.8 CANOE REMOVAL

It is the responsibility of the participating schools to remove their entire canoe and any associated debris from the host site after the competition. ACI Malaysia has the option to remove any remaining canoe debris from the site and bill the responsible school.

## 1.9 SAFETY

It is the responsibility of all participants to comply with Department of Occupational Safety and Health Malaysia (DOSH, <http://www.dosh.gov.my/>) policies. It is the responsibility of all participants to know about the materials with which they are working. Participants should obtain and read Safety Data Sheets (SDS) for each material with which they will be working. It is the responsibility of all participants to work in a safe manner in a safe workplace environment.

# 2 CONCRETE CANOE

## 2.1.1 GENERAL

The canoe shall pass a flotation test where the canoe breaks the water's surface, when completely filled with water. The canoe shall be certified as safe before entering any race to the satisfaction of the judges. Canoes that do not pass the flotation test will be disqualified.

## 2.2 DIMENSIONAL CONSTRAINTS

### 2.2.1 Length

The length of the canoe, defined as the maximum end-to-end (bow to stern) measurement taking into account the outermost longitudinal dimension of the hull, is restricted to 4.5 metre.

## 2.3 CONCRETE AND REINFORCEMENT

All concrete mixtures shall comply with all of the rules and regulations presented in Section 3 – CONCRETE. All materials which are not part of a concrete mixture, with the exception of materials that are used for flotation, shall be classified as a reinforcing material and shall comply with all of the specifications presented in Section 4 - REINFORCEMENT.

## 2.4 PADDLES

Canoes shall be paddled and not rowed. Paddles shall be single-bladed and may be straight bladed or bent. Spare paddles are permitted in the canoe during the races. **Paddles are to be prepared by participants.**

## 2.5 SLIP RESISTANT MATERIAL

The use of non-skid tape or other slip resistant material is not permitted.

## 2.6 FLOTATION

### 2.6.1 Requirements

The intent of the flotation test is to ensure that canoes will break the water's surface so that they can be recovered in the event the canoe becomes submerged during the course of a race. Canoes are to be able to pass the flotation test either by the inherently buoyant design of the canoe (i.e., lightweight concrete) or through the incorporation of flotation material in the design. For safety reasons, no hollow cavities or air bladders are permitted. Flotation material shall be solid blocks of material. Canoes that failed in the test are not eligible to participate in the race.

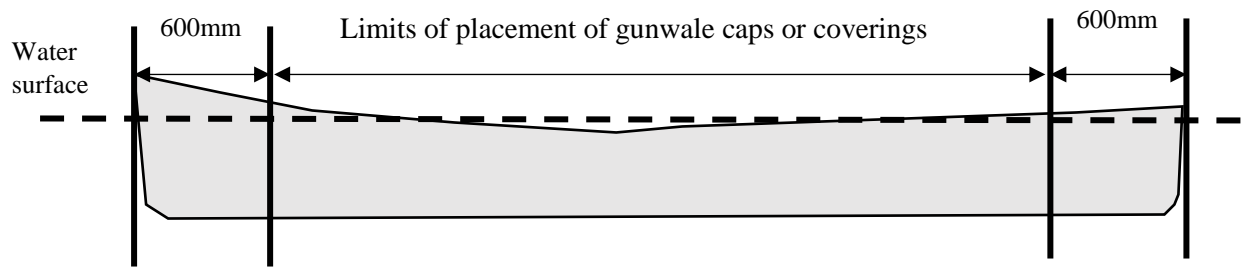

\* Caps and covering not permitted during floatation test

Figure 2.1 Limits of Rigid Gunwale Protection (Not to Scale)

## 2.6.2 Flotation Test

The canoe shall pass a flotation test whereby the canoe floats horizontally, with both ends breaking water's surface, within two (2) minutes of being completely filled with water (see the Figure 2.2).

Teams have a maximum of ten (10) minutes to fully submerge and remove their canoe from the flotation tank or body of water where testing is being conducted. Teams are encouraged to bring their own supplies (i.e., buckets) to ensure that their canoe can be submerged and removed within the required time period. Teams shall submerge their canoe by whatever means necessary (such as, filling the canoe with buckets of water, tilting the canoe so that water fills in, pushing it downward, etc.) and are solely responsible for handling the canoe to meet the requirements of the test.

A canoe shall be deemed as successfully passing the flotation test if it floats level and breaks the surface of the water without sinking once completely submerged.

## 2.7 REPAIRS

### 2.7.1 Repairs Made During Competition

During the competitions, inclusive of all events and transportation to and from the events, repairs can be made only with tape. Any type of tape is allowed. The repair shall be conducted under the supervision of MCCC committee and up to the judge's decision to allow the proposed repair.

### 2.7.2 Repair Materials

Pre-packaged or pre-mixed concrete, mortar, or grout is not permitted in the construction or repair of the canoe. Poly urethane, epoxy, or similar materials are not permitted as patching or filler material at any time during the construction of the canoe, as a legal repair material for the canoe during the competitions.

## 3 CONCRETE

### 3.1 GENERAL

Concrete mixtures are considered as unique and independent mixes and shall comply with all of the requirements of this section. Pre-packaged or pre-mixed concrete, mortar, or grout is not permitted. Poly urethane, epoxy or similar materials are not permitted during the casting of the canoe (i.e., placement of concrete, reinforcement and flotation). Mixtures used as filler and patching materials during the construction of the canoe, including repairs during initial

construction such as cracks, “bug holes,” low spots, etc., shall meet all of the requirements of this section.

## 3.2 REQUIREMENTS

### 3.2.1 Cement

The cement binder could be hydraulic or non-hydraulic (or a combination of these two cement).

### 3.2.2 Density

#### 3.2.2.1 *Fresh concrete density*

The fresh concrete density should be determined based on BS EN 12350-6.

#### 3.2.2.2 *Hardened concrete density*

The oven dried density of concrete should be determined based on BS EN 12390-7.

## 3.3 Documentation

### 3.3.1 Mix Proportion Table

The mix proportions of any concrete mixture used in building the canoe should be summarised in Table 3.1 (Concrete mixture data table) and should be included in **Appendix** in design papers. **Participants should be responsible for the accuracy and correct determination of all values and proper use of significant figures.**

### 3.3.2 Engineering properties

The fresh and hardened engineering properties such as concrete density, strengths and air content shall be reported in SI unit and determined with industry standards (e.g. BS EN 12350-6, BS EN 12350-7, BS EN 12390-3, BS EN 12390-6, BS EN 12390-7, etc.) on the design paper.

### 3.3.3 Material Data Sheets (MDS)

Material Data Sheets (MDS) for each material used in the canoe construction should be presented under Appendix of the Design Papers (Section 6.0). This includes, but is not limited to, cementitious materials, aggregate (other than natural or manufactured sands), admixtures, and pigments. Material Safety Data Sheets (MSDS) are not equivalent documentation for MDS.

For unaddressed equivalent materials shall be submitted to and approved by the MCCC as alternatives prior to their application.

### 3.3.4 Aggregate Sample(s)

A minimum 500 millilitre (ml) samples representative of both the individual aggregates and composite aggregate blends used in each concrete mixture shall be made available as part of the product display. Samples shall be labelled accordingly and provided in transparent containers.

### 3.3.5 Concrete Sample(s)

A 100 mm diameter cylindrical sample of each concrete mixture used in the canoe shall be made available for compliance checking as part of the product display. The sample (s) shall be a quality (QC) test sample taken during the construction. It must be representative of the in-place density, colour, consistency and make-up of the concrete (s) used in the canoe.



## Rules and Regulations for Malaysian Concrete Canoe Competition 2017

The concrete cylinder shall be provided. In two halves, preferable sawn in half, or broken by performing a splitting tensile test (BS EN 12390-6).

Participants should also bring a long one (1) complete (unbroken) 100 mm diameter cylindrical sample of each concrete mixture used in the concrete canoe construction for density verification. This sample should be prepared according to BS EN 12390-2.

**Participants shall make sure all the submitted samples during the competition are oven-dried.**

In case of doubt, powdered sample will be obtained from the canoe and oven dried sample to undergo X-ray fluorescence spectrometry analysis.



Table 3.1 Summary of Mix Design

<b>Cementitious material (CM)</b>	<b>Type/Name/Label</b>	<b>Specific Gravity</b>	<b>Weight (kg/m<sup>3</sup>)</b>				
<b>Cement, EN 197</b>							
<b>Cementitious 1</b>							
<b>Cementitious 2</b>							
<b>Cementitious 3</b>							
<b>Cementitious 4</b>							
		Total					
<b>Fibres (F)</b>	Type/Name/Label	Specific Gravity	Weight (kg/m <sup>3</sup> )				
<b>Fibre 1</b>							
<b>Fibre 2</b>							
<b>Fibre 3</b>							
		Total					
<b>Aggregate (AGG)</b>	Type/Name/Label	Saturated Surface Dried (SSD) Specific Gravity	Weight (kg/m <sup>3</sup> )				
<b>Aggregate 1</b>							
<b>Aggregate 2</b>							
<b>Aggregate 3</b>							
		Total					
<b>Liquid Admixtures (LA)</b>	Type/Name/Label	Specific Gravity	Weight (kg/m <sup>3</sup> )				
<b>Admixture 1</b>							
<b>Admixture 2</b>							
<b>Admixture 3</b>							
		Total					
<b>Solid Admixtures (SA)</b>	Type/Name/Label	Specific Gravity	Weight (kg/m <sup>3</sup> )				
<b>Powdered Admixture 1</b>							
<b>Powdered Admixture 2</b>							
<b>Powdered Admixture 3</b>							
		Total					
<b>Water (W)</b>	-	Specific Gravity	Weight (kg/m <sup>3</sup> )				
<b>Free water content</b>	-	Total					
<b>Densities, Air content, Ratios, and Slump</b>							
	CM	F	AGG	LA	SA	W	Total
<b>Mass of concrete (kg/m<sup>3</sup>)</b>							
<b>Wet Density Measured (kg/m<sup>3</sup>)</b>				Slump/ Flow (mm)			
<b>Oven Dried Density Measured (kg/m<sup>3</sup>)</b>				Air content (%)			
<b>Water-cement ratio</b>				Water-CM ratio			

## 4 REINFORCEMENT

#### 4.1 GENERAL

All primary reinforcement shall not be exposed. The materials which are not part of a concrete mixture shall be classified as reinforcing material and they shall meet the requirement of the specifications outlined below. This does not apply to the floatation materials.

#### 4.2 MATERIALS

All primary reinforcement in the canoe shall have adequate open space to allow for the mechanical bonding of the concrete composite. The determination of sufficient open space of the reinforcement is measured by percent open area (POA) as defined in Section 4.3.1.

**Solid mats or plates for reinforcing are not permitted.** Fibres that are dispersed into the concrete are considered to be a secondary reinforcement.

#### 4.3 MEASUREMENT

##### 4.3.1 Percent Open Area (POA)

The minimum Percentage Open Area (POA) is 40%. The POA is calculated using the equation below:

$$POA = \frac{\sum Area_{open}}{\sum Area_{total}} \times 100\%$$

Where:

$\sum Area_{open}$  is the total open area (i.e., the area of the apertures)

$\sum Area_{total}$  is the total area of the reinforcement specimen

##### *For example:*

Given: A fibre reinforcing mesh with a 64 square millimetre aperture size (8 mm by 8 mm aperture dimensions). The thickness of fibres along the sample length was determined to be 3 mm wide while the thickness along the sample width was found to be 5.00 mm wide.

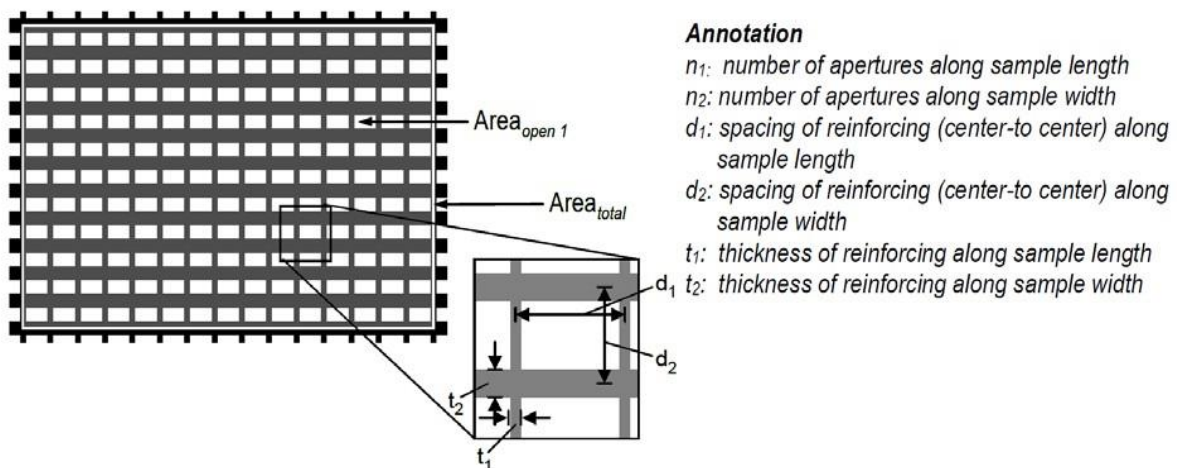

$$d1 = \text{aperture dimension} + 2(t1 / 2) = 8 + 2(3/2) = 11 \text{ mm}$$

$$d2 = \text{aperture dimension} + 2(t2 / 2) = 8 + 2(5/2) = 13 \text{ mm}$$

$$\text{Length}_{\text{sample}} = n1d1 = [(15) \times 11] = 165 \text{ mm}$$

$$\text{Width}_{\text{sample}} = n2d2 = [(11) \times 13] = 143 \text{ mm}$$

$$\Sigma \text{Area}_{\text{open}} = n1 \times n2 \times \text{Area}_{\text{open}} = 15 \times 11 \times 64 \text{ mm}^2 = 10560 \text{ mm}^2$$

$$\text{Width}_{\text{sample}} = n2d2 = [(11) \times 13] = 143 \text{ mm}$$

$$\Sigma Area_{open} Area_{total} = Length_{sample} \times Width_{sample} = 165 \times 143 = 23595 \text{ mm}^2$$

$$POA = \frac{\sum Area_{open}}{\sum Area_{total}} \times 100\% = 10560 / 23595 \times 100 = 45\%$$

#### 4.4 DOCUMENTATION

##### 4.4.1 Reinforcement and Percent Open Area (POA) Calculations

The measurements and calculations of the reinforcement(s) Percent open area (POA) calculations of each of the reinforcement types used shall also be presented under Tab C.

##### 4.4.2 Reinforcement Samples

A minimum 300 mm x 300 mm. square sample of each reinforcement material used in the canoe shall be made available for compliance checking and product display. If bars, tendons or strands are utilized, a sample of with a minimum length of 300 mm length shall be provided.

##### 4.4.3 Material Technical Data Sheets

Material Data Sheets (MDS) for each reinforcement material used in the construction of the canoe shall be presented under Appendix of the Design Papers.

### 5 FINISHING

#### 5.1 GENERAL

All Material must be environmentally safe.

#### 5.2 LETTERING

The school name (no initials) and the canoe name shall be prominently displayed on the exterior of the canoe, above the waterline, on both sides, with individual (not a continuous decal) letters.

#### 5.3 GRAPHICS

Graphics such as logos, symbols, etc. created using concrete colouring agents and pigments within the concrete mix design (i.e., integrally coloured concrete) are not limited in dimension or frequency.

The colouring agents or pigments used shall be in accordance with BS EN 12878. Teams are responsible to ensure the colouring agents used should **not pollute/contaminate** the surrounding environment.

#### 5.4 DOCUMENTATION

##### 5.4.1 Material Data Sheets

Material Data Sheets (MDS) for each material used in the construction of the canoe shall be filed under Appendix of the Design Papers. This includes, but is not limited to pigments, sealers and curing compounds.

## 6 DESIGN PAPER

### 6.1 GENERAL REQUIREMENTS

The design paper shall be present on white A4 size paper in portrait orientation. The body text shall be in English with font size 12-point, normal width character spacing, Times New Roman or Arial font, and at least single spaced. Section headings and subheadings may be any legible font size.

The content of the design paper includes an executive summary, project management, material development & testing and any other relevant details regarding the design & construction of concrete canoe.

The appendix of design paper must consists of references, mixture proportions, material data sheet, percentage Open Area (POA) of Primary Reinforcement and other relevant calculation/analysis data.

### 6.2 REPORT SUBMISSION

All 6 bound copies of the design paper must be received no later than 5.00 pm 14<sup>th</sup> July 2017 at the following address:

**ACI Malaysia**

No. 70-1, Jalan PJS 5/30,  
Pusat Dagangan Petaling Jaya Selatan (PJCC),  
46150 Petaling Jaya, Selangor, Malaysia.

The electronic design paper shall be considered the official and final version of the design paper. The electronic design paper must be received no later than 5.00 pm 14<sup>th</sup> July 2017 at the following email address. **Penalties will be assessed for late, partial or incomplete submissions.**

**Email: [mymccc2017@gmail.com](mailto:mymccc2017@gmail.com)**

## 7 RACE RULES and REGULATIONS

### 7.1 GENERAL

A total of five (5) races shall typically be held: men's endurance (2 men), women's endurance (2 women), men's sprint (2 men), women's sprint (2 women), and co-ed sprint (1 man and 1 woman).

### 7.2 RACE RULES

The following general rules apply to the paddlers:

- a. Good faith efforts are made to start and finish all races. Should issues arise that may compromise the structural integrity of the canoe or the safety of the paddlers, teams must exercise good judgment in determining the best course of action (the safety and structural integrity must be maintained; please do not attempt to circumvent the Rules on technicalities).
- b. Head Judges are to be advised of all issues that arise (such as structural damage) in a timely manner so that they are aware of the situation and knowledgeable of the course of action to be undertaken.
- c. Teams shall use the same individuals in both the preliminary and final heats of any particular race.
- d. In the event that a paddler is injured prior to a preliminary race, a substitution may be made. This substitute paddler shall be from one of the original five (5) of the same gender registered on the team.
- e. In the event of an injury that prevents a paddler from further competition after the preliminary race has been completed, the injured person or a substitute shall be in the canoe in subsequent races. However, this person or these persons shall not be allowed to paddle. The substitute passenger shall be from one of the original five (5) of the same gender registered on the team.
- f. In the event that a team cannot field the proper number of paddlers of the required gender, substitute passengers of opposite gender shall be allowed, **but these substitutes shall not be allowed to paddle**. Substitute passengers shall be of the team's registered participants.
- g. In a situation where none of the race events can take place, the overall competition score shall be based solely on the results of the academic portion of the competition (Design Paper, Oral Presentation, and Final Product).

### 7.3 SPORTSMANSHIP

Commonly accepted rules of sportsmanship shall be followed. There shall be strict enforcement of racing etiquette by the MCCC judges. Any canoe wilfully interfering with the performance of any other canoe in a race shall be automatically disqualified.

Any use of paddles to intentionally strike at an opponent's canoe, or at any person, shall be

considered as disqualified. Good sportsmanship, cooperation, fellowship, and the spirit of competition shall be strictly adhered to.

Spectators interfering with the performance of contestants shall be asked to leave and may cause the disqualification of affiliated contestants. Contestants or spectators interfering with the performance of the competition, judges' ruling, or protests, may cause the disqualification of the affiliated school.

#### 7.4 RACE COURSE

##### 7.4.1 General Requirements

The bow of the canoe shall remain the bow of the canoe throughout each race.

##### 7.4.2 200-meter Endurance Course

The endurance course shall consist of the following subject to site conditions:

- a. A total of 200 meters in distance
- b. The MCCC reserves the right to modify the location and layout of the slalom portion of the course.

##### 7.4.3 100 Sprint Course

A sprint course shall consist of the following subject to site conditions:

- a. Men's and women's sprint course will be a straight course 100 meters in distance.
- b. The co-ed race will be a 100-meter race.
- c. The MCCC reserves the right to modify the location and layout of the slalom portion of the course.

#### 7.5 RACE PENALTIES

The following corresponding penalties shall be assessed as defined below:

- a. A canoe that crosses the finish line in the wrong lane shall be assessed a 30-second time penalty for that particular event.
- b. For a team to successfully finish a given race, the bow of the canoe must cross the finish line with the same number of paddlers (in the canoe or touching the canoe) with which the race began.
- c. Safety officials reserve the right to use their best judgment to remove a swamped canoe and paddlers from the racecourse if the situation warrants.